



SERIES 10S

ONE-PIECE UNIBODY BALL VALVE



FEATURES

- For General Purpose Industrial Application
- Investment Cast Stainless Steel Unibody
- Various Thread Standards Available:
 - PF
 - PT
 - NPT
- Blow-Out Proof Stem
- Double Reduced Port
- Cost competitive
- Sizes Available from 1/4" to 2" (1000 WOG)

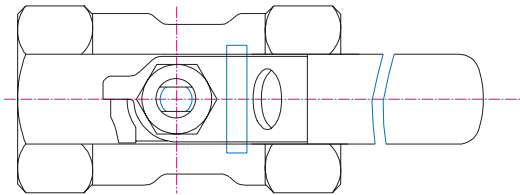

TOP VIEW

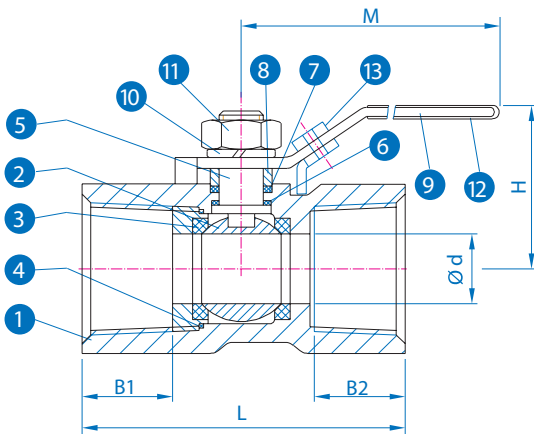

MATERIAL LIST

NO.	PART NAME	MATERIAL	Q'TY
1	BODY	CF8M / 1.4408	1
2	BALL	ASTM A351 Gr CF8M	1
3	SEAT	PTFE	2
4	INSERT	ASTM A351 Gr CF8M	1
5	STEM	316SS	1
6	THRUST WASHER	PTFE	1
7	STEM PACKING	PTFE	1
8	GLAND RING	304SS	1
9	HANDLE	304SS	1
10	STEM WASHER	304SS	1
11	STEM NUT	304SS	1
12	HANDLE SLEEVE	VINYL	1
*13	LOCKING DEVICE	304SS	1

* OPTIONAL

DIMENSIONS (mm)

SIZE	DN	Ød	B1	B2	L	H	M	WT (kg)
1/4"	8	5.0	10.0	9	39.0	38.0	62.5	0.072
3/8"	10	7.0	10.0	8	44.0	40.0	73.0	0.114
1/2"	15	9.2	14.0	13	56.5	51.0	85.0	0.193
3/4"	20	12.5	13.5	14	59.0	53.5	87.0	0.274
1"	25	16.0	16.5	16	71.0	56.0	107.0	0.430
1-1/4"	32	20.0	17.5	17	78.0	61.5	107.0	0.717
1-1/2"	40	25.0	18.5	17	83.0	68.0	130.0	0.870
2"	50	32.0	21.5	18	100.0	73.0	130.0	1.364